

Manufactured by



394 Dairy Pak Rd. • Athens, GA 30607
kdframes.com • alan@kdframes.com

Instructions for Savannah Lounger Twin #7244

Tools needed:

- #2 Phillips Screw Driver
- Small Hammer

PARTS

(2) L-40 STRETCHER (40")

(2) L-39 BACK SLAT (39")

(2) L-37 SEAT SLAT (37")

(2) L-35 LOUNGER SLAT (35")

(2) LM-35 BACK MIDDLE SLAT (35")

(2) LM-33 SEAT MIDDLE SLAT (33")

(1) LM-31 LOUNGER MIDDLE SLAT (31")

(1) L-41 LEG CONNECTOR (35")

(4) L-16 SLAT CAPS (18")

(2) L-17 LOUNGER SLAT CAPS (10")

(2) L-14 LOUNGER LEG (12")

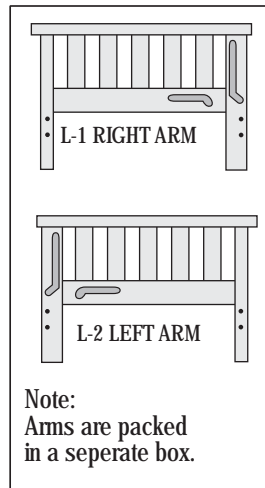

(2) L-20 BACK RAILS (27")

(2) L-21 SEAT RAILS (27")

(2) L-22 LOUNGER RAILS (24")

HARDWARE LIST

H-1	3" BOLT		8	H-6	WASHER		6
H-3	CROSS DOWEL		8	H-11	WOOD DOWEL		28
H-8	CLEVIS PIN		10	H-19	1 1/2" SCREW		14
H-5	HAIR PIN		6	H-10	HEX WRENCH		1
H-9	PLASTIC ROLLER		4				

1

Use a small hammer to tap Wood Dowels (H-11) all the way into holes as shown.

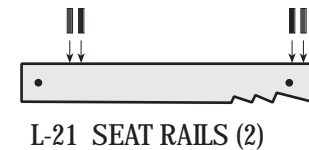
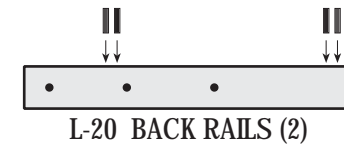
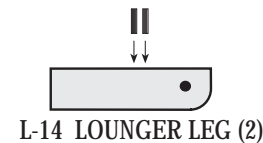

2

Find the (2) LM-35 Back Middle Slats and press them into (2) L-16 Slat Caps.

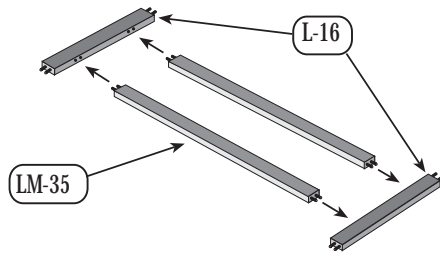

3

Find the (2) L-39 Back Slats and press them onto the Slat Caps as shown.

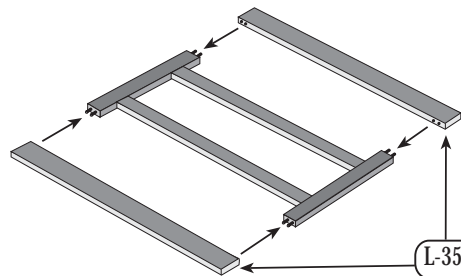

4

Find the (2) L-20 Back Rails. Press the slat deck onto the wood dowels and attach with (4) Wood Screws (H-19).

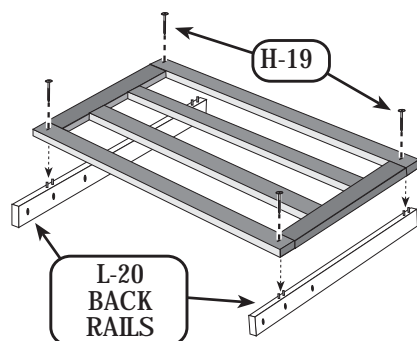

5

Find the (2) LM-33 Seat Middle Slats and press them into (2) L-16 Slat Caps.

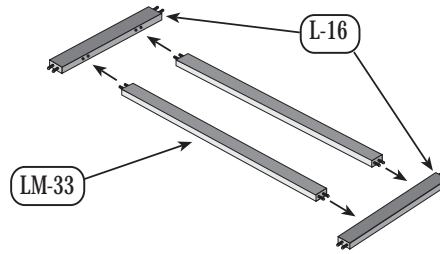

6

Find the (2) L-37 Seat Slats and press them onto the Slat Caps as shown.

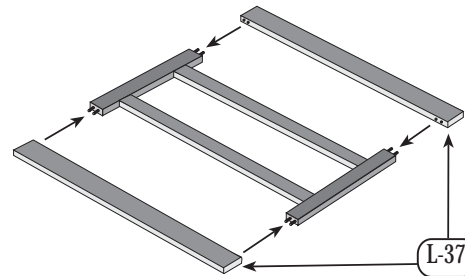

7

Find the (2) L-21 Seat Rails. Press the slat deck onto the wood dowels and attach with (4) Wood Screws (H-19).

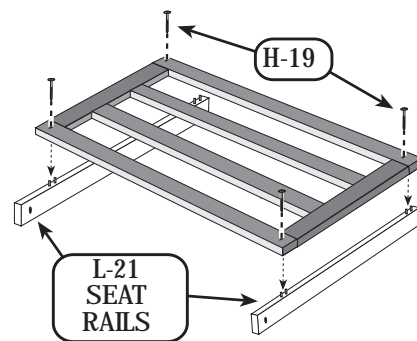

8

Find the LM-31 Lounger Middle Slat and press into (2) L-17 Lounger Slat Caps.

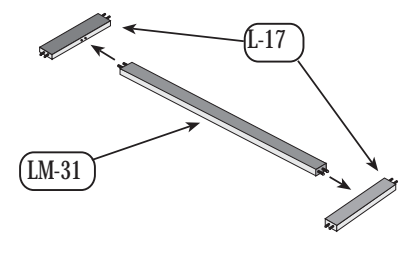

9

Find the (2) L-35 Lounger Slats and press them onto the Slat Caps as shown.

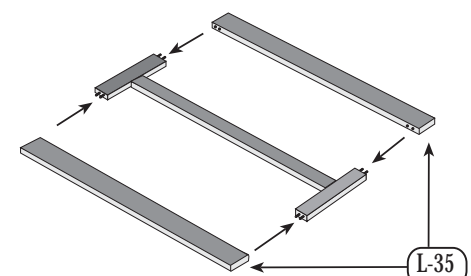

10

Find the (2) L-22 Lounger Rails. Press the slat deck onto the wood dowels and attach with (4) Wood Screws (H-19).

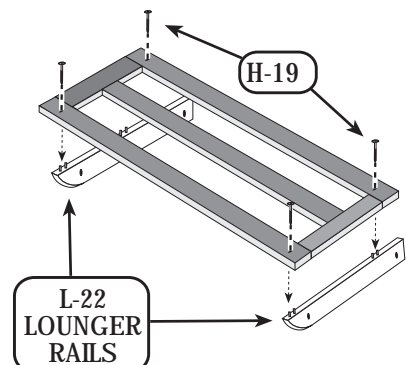

11

Attach the Plastic Rollers (H-9) to the Back Caps with Clevis Pins (H-8).

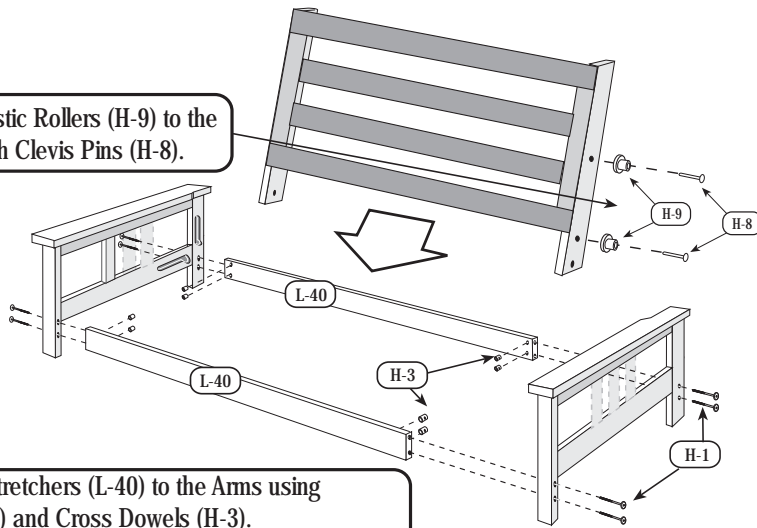

- Attach the Stretchers (L-40) to the Arms using 3" Bolts (H-1) and Cross Dowels (H-3). Leave all of the bolts loose at this time.
- Carefully put the back in place, making sure that the rollers go into the slots.
- When all 4 rollers are in the 4 slots, tighten the bolts.

12

Attach the Seat to the Back using the Clevis Pins (H-8). Secure the Clevis Pins with the Hair Pins (H-5).

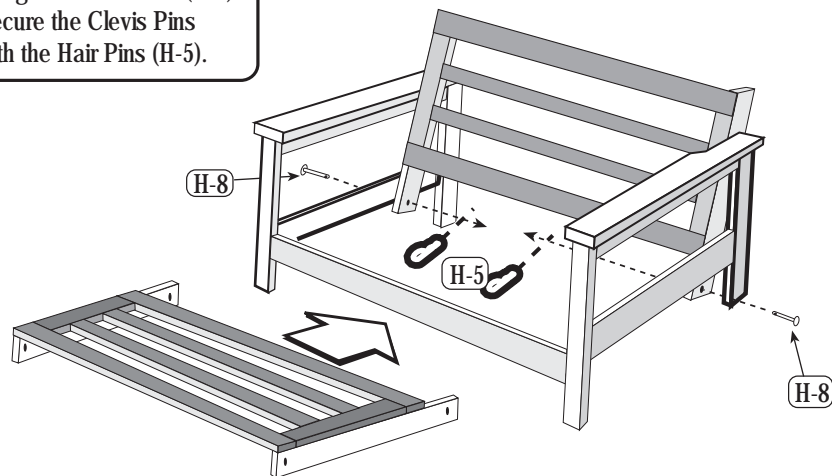

13

- Pull forward on the Seat to convert to the bed position.
- Attach the Lounger to the Seat using Clevis Pins (H-8).
- Attach the Lounger Legs (L-14) to the Lounger using Clevis Pins (H-8).
- Secure the Clevis Pins with Washers (H-6) and Hair Pins (H-5).
- Attach the Leg Connector (L-51) using 1 - 1/2" Wood Screws (H-19).

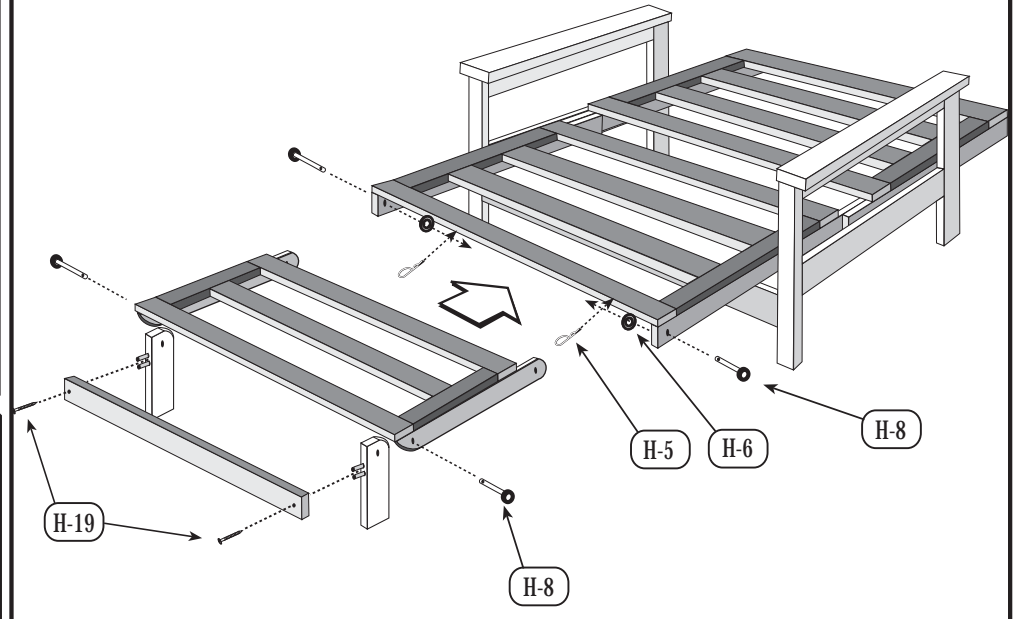

Knockdown Frameworks, Inc. warrants all of its products for five years against any defects that are due to faulty materials or workmanship. We will promptly correct such defects by repair or replacement, at our option, without charge. This warranty covers product defects only and will expire five years after date of purchase by the original consumer purchaser, with proof of purchase required.

This warranty does not apply to damage caused by and resulting from misuse, neglect, accident, or improper operation, maintenance, storage, transportation, or handling of the product. This warranty is for the original consumer purchaser for residential use only and does not apply if the product is used in any commercial application (such as rental property). This warranty does not cover any incidental or consequential damages. If you feel that you have a claim under this warranty, please contact the store from which it was purchased. If this is not possible, call 800-543-3393 for advice on handling your claim.

Operation:

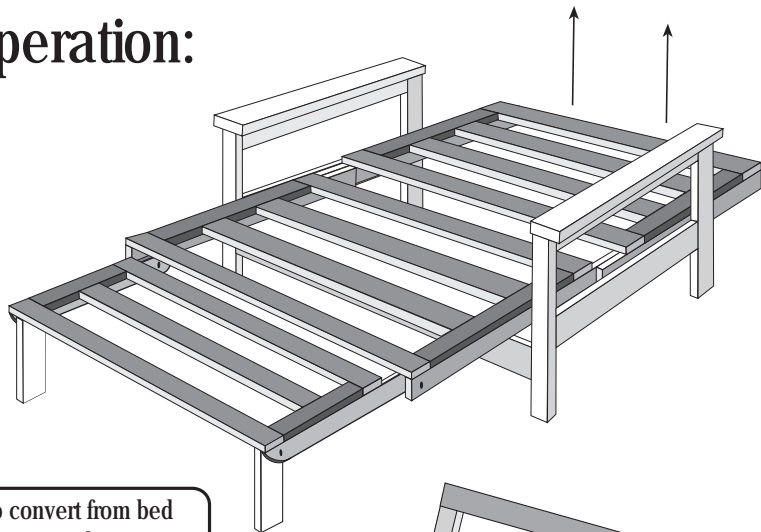

To convert from bed position to lounger, lift up the back section.

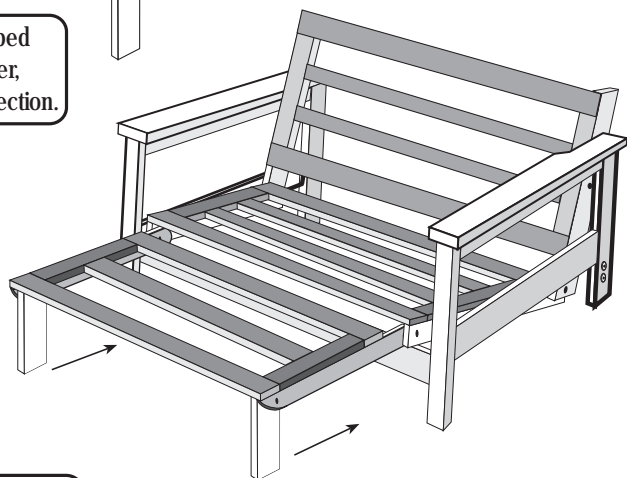

Then fold Lounger Legs under Lounger section.

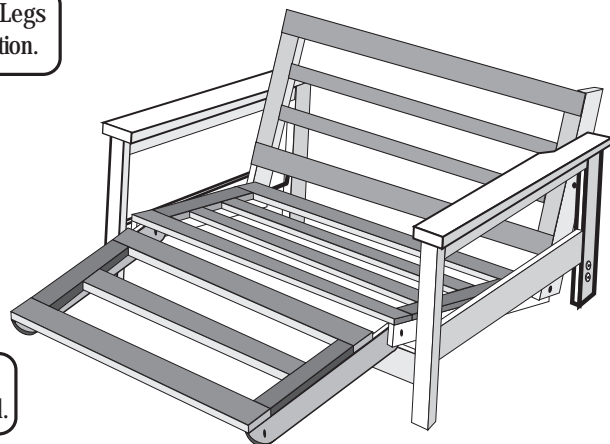

Reverse steps to convert back to bed.

To convert from bed to chair, you must start in the bed position.

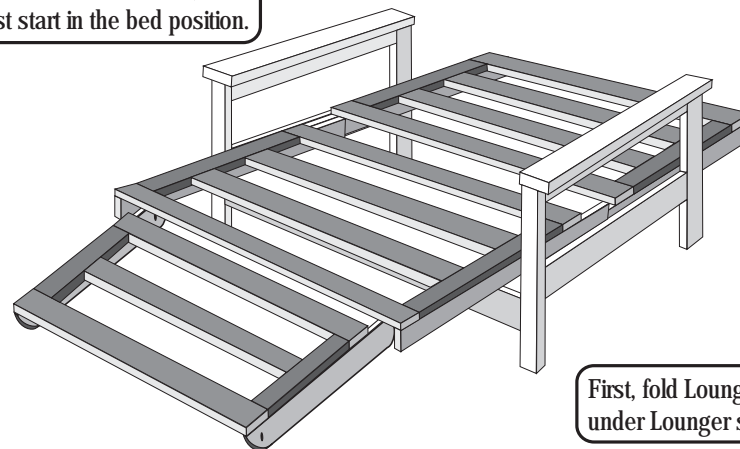

First, fold Lounger Legs under Lounger section

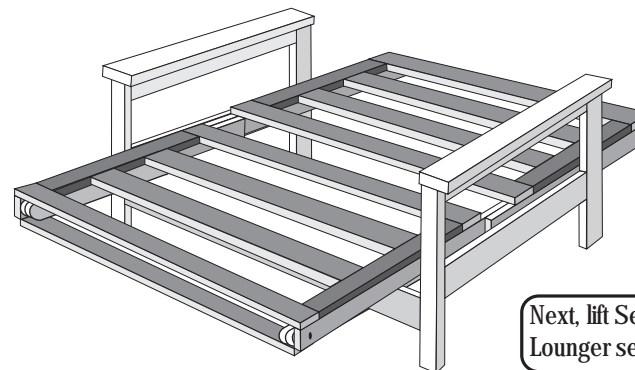

Next, lift Seat and fold Lounger section under.

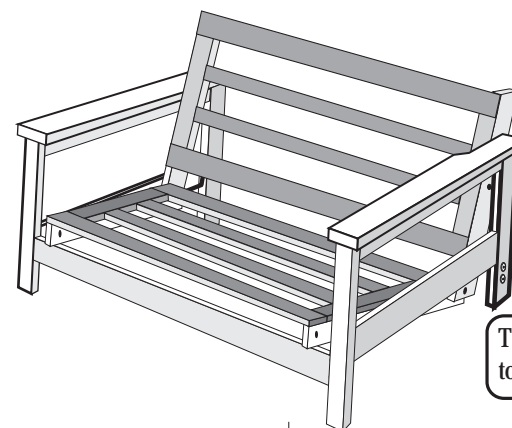

Then lift back to convert to Chair position.