

Instructions for TV Table

Manufactured by



394 Dairy Pak Rd. • Athens, GA 30607
kdframes.com • alan@kdframes.com

PARTS LIST

T-10	26" TOP RAILS	2	H-21	2 - 1/2" BOLTS		4
T-13	22" LEGS	4	H-3	CROSS DOWELS		4
T-5	14" LEG CONNECTORS	4	H-4	2" WOOD SCREWS		8
T-6	16" TOP SLATS	9	H-19	1 1/2" SCREWS		8
T-7	16" CONNECTOR SLATS	2	H-10	"Z" WRENCH		1
T-14	26" SHELF RAILS	2	H-10	DRIVER BIT		1
T-12	13" SHELF SLATS	6				



T-13 LEGS (4)

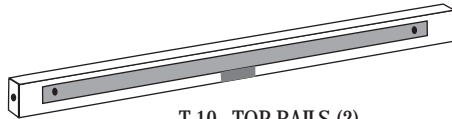

T-10 TOP RAILS (2)

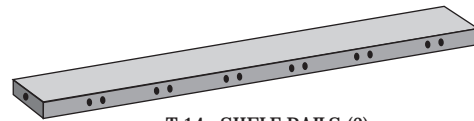

T-14 SHELF RAILS (2)

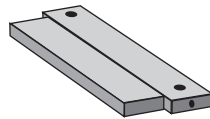

T-7 CONNECTOR SLATS (2)

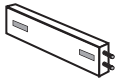

T-5 LEG CONNECTORS (4)

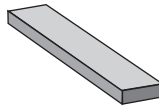

T-6 TOP SLATS (9)

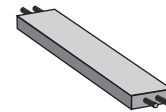

T-12 SHELF SLATS (6)

1

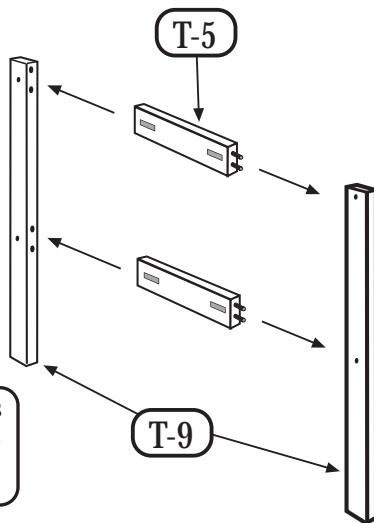

Push (2) T-5 Leg Connectors into the holes on (2) T-9 Legs.

Repeat for the other side.

2

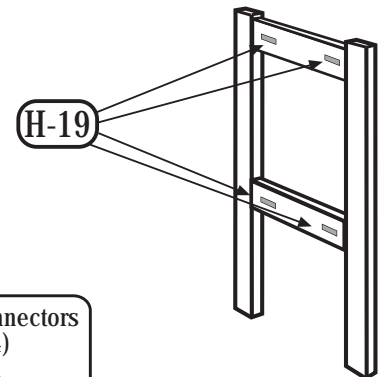

Secure the Leg Connectors to the Legs using (4) H-19 Wood Screws.

Knockdown Frameworks, Inc. warrants all of its products for five years against any defects that are due to faulty materials or workmanship. We will promptly correct such defects by repair or replacement, at our option, without charge. This warranty covers product defects only and will expire five years after date of purchase by the original consumer purchaser, with proof of purchase required.

This warranty does not apply to damage caused by and resulting from misuse, neglect, accident, or improper operation, maintenance, storage, transportation, or handling of the product. This warranty is for the original consumer purchaser for residential use only and does not apply if the product is used in any commercial application (such as rental property). This warranty does not cover any incidental or consequential damages. If you feel that you have a claim under this warranty, please contact the store from which it was purchased. If this is not possible, call 800-543-3393 for advice on handling your claim.

3

Assemble the Shelf by pushing (6) Shelf Slats T-12 into the holes on the (2) Shelf Rails T-14.

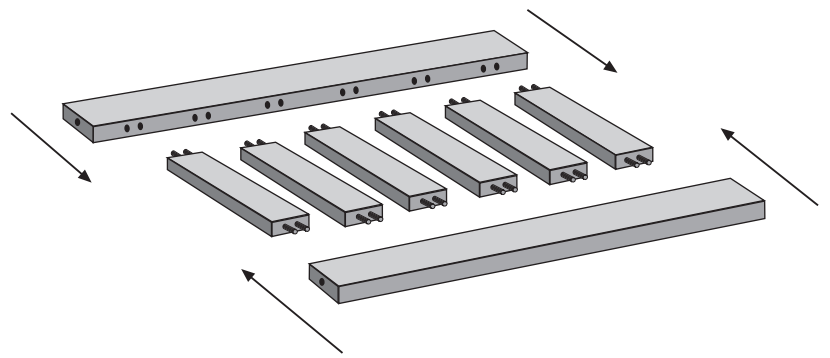

4

ATTENTION:

Assemble the Table Top upside down as shown.

Use (4) 2-1/2" Bolts and Cross Dowels to attach the Top Rails T-10 to the Connector Slats T-7.

Leave the bolts loose at this time.

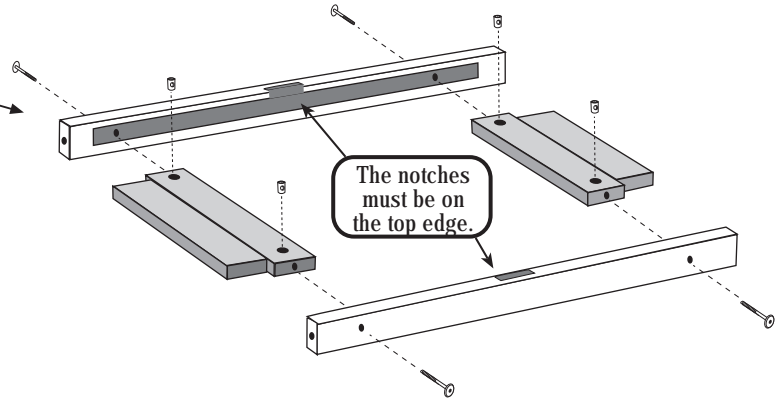

5

Insert (9) Top Slats T-6 using the two notches provided in the Top Rails.

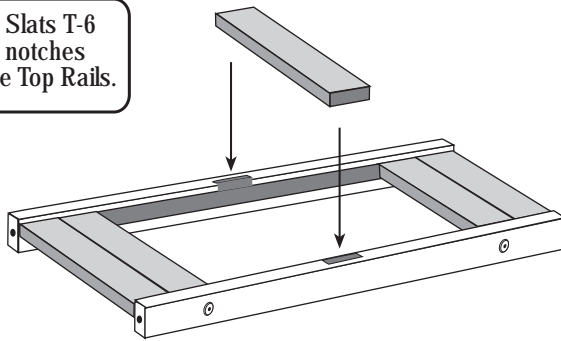

6

Slide the Top Slats to each end. When all the slats are in, tighten the bolts.

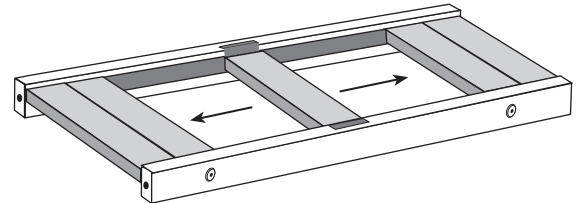

7

Don't forget to turn the top right side up.

Attach the Legs to the Table Top and Shelf using (8) Wood Screws H-4.

Please retighten screws after 30 days.

