

Instructions for Charleston Headboard Queen # 7991

Manufactured by



394 Dairy Pak Rd. • Athens, GA 30607
kdframes.com • alan@kdframes.com

H A R D W A R E L I S T

H-2	3 - 1/2" BOLT		8
H-10	HEX WRENCH		1
H-19	1 1/2" SCREW		4

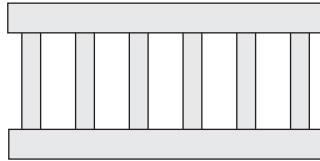

N-7 HEADBOARD CENTER SECTION (1)

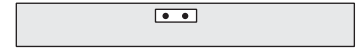

N-8 HEADBOARD LEG (2)

1

Carefully align Headboard parts as shown and press the Legs onto the center section.
Note:
You must make sure that the rail pockets are aligned as shown.

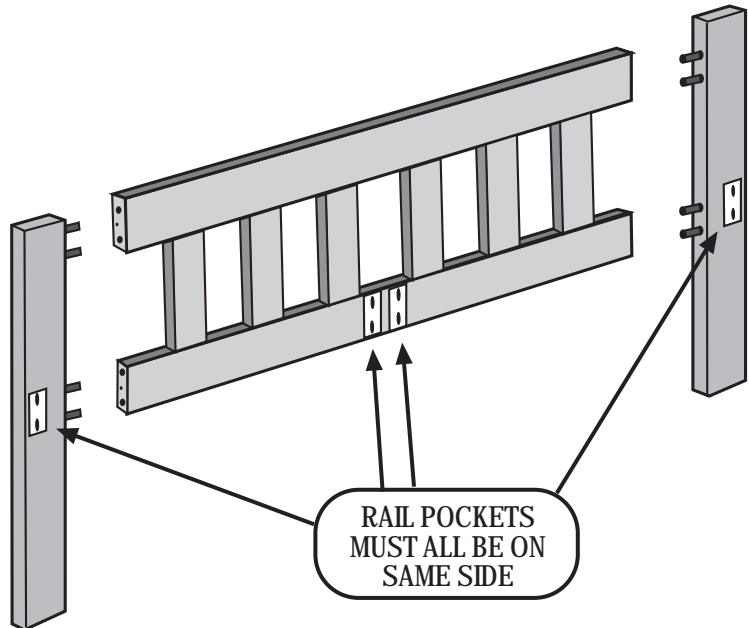

2

Now turn the Headboard over and secure the Headboard Legs with (4) Wood Screws (H-19).

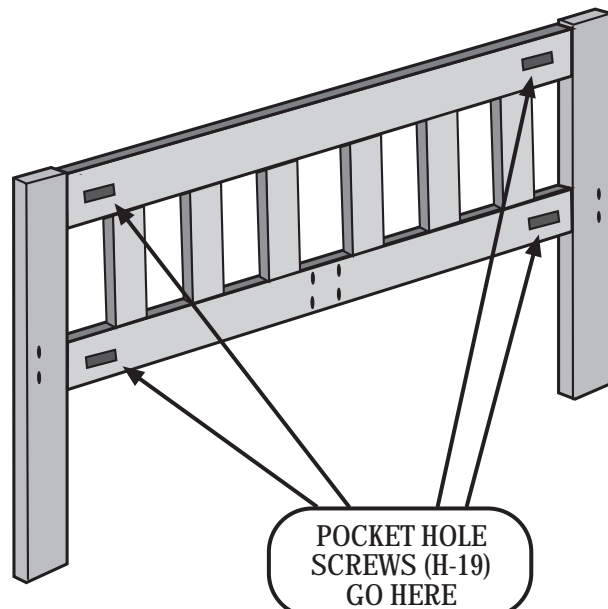

3

Use (8) 3-1/2" Bolts (H-2) to attach the Headboard over the Bed End. Bolts should go through the Headboard and the Bed End.

If you prefer, you can leave off the Bed End and just use the Headboard. (Use the 3" Bolts that came with the bed.)

NOTE:

In general, futon mattresses are a little shorter than traditional mattresses. So if you are using a traditional mattress, it would be better to leave the Bed End on the bed, and if you are using a futon mattress, then leave it out.

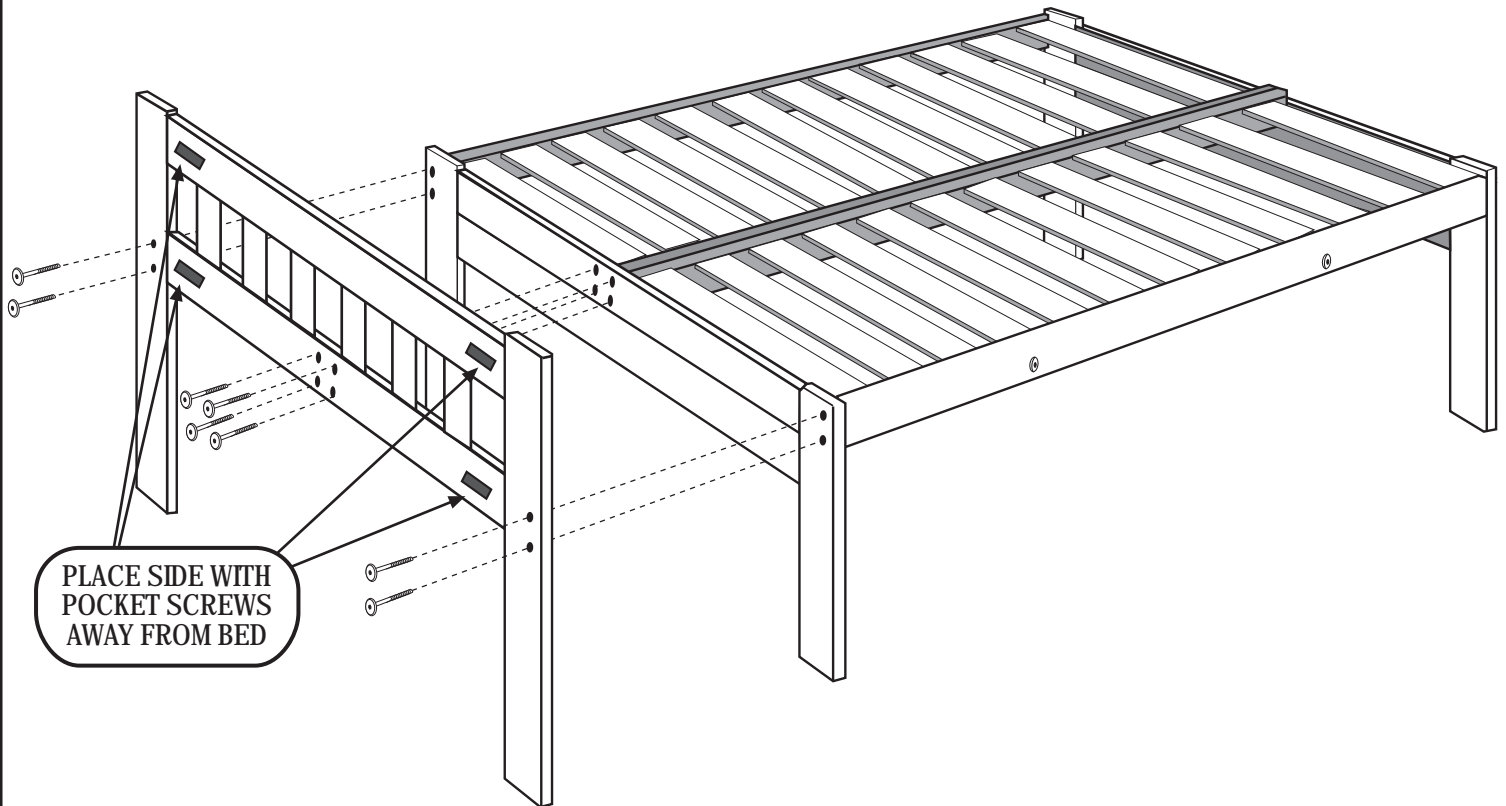

Knockdown Frameworks, Inc. warrants all of its products for five years against any defects that are due to faulty materials or workmanship. We will promptly correct such defects by repair or replacement, at our option, without charge. This warranty covers product defects only and will expire five years after date of purchase by the original consumer purchaser, with proof of purchase required.

This warranty does not apply to damage caused by and resulting from misuse, neglect, accident, or improper operation, maintenance, storage, transportation, or handling of the product. This warranty is for the original consumer purchaser for residential use only and does not apply if the product is used in any commercial application (such as rental property). This warranty does not cover any incidental or consequential damages. If you feel that you have a claim under this warranty, please contact the store from which it was purchased. If this is not possible, call 800-543-3393 for advice on handling your claim.